

hallicrafters

OPERATING AND SERVICE INSTRUCTIONS

**MODEL HA-6
SIX-METER
TRANSVERTER**

WARRANTY

"The Hallicrafter's Company warrants each new radio product manufactured by it to be free from defective material and workmanship and agrees to remedy any such defect or to furnish a new part in exchange for any part of any unit of its manufacture which under normal installation, use and service discloses such defect, provided the unit is delivered by the owner to our authorized radio dealer, wholesaler, from whom purchased, or, authorized service center, intact, for examination, with all transportation charges prepaid within ninety days from the date of sale to original purchaser and provided that such examination discloses in our judgment that it is thus defective.

This warranty does not extend to any of our radio products which have been subjected to misuse, neglect, accident, incorrect wiring not our own, improper installation, or to use in violation of instructions furnished by us, nor extended to units which have been repaired or altered outside of our factory or authorized service center, nor to cases where the serial number thereof has been removed, defaced or changed, nor to accessories used therewith not of our own manufacture.

Any part of a unit approved for remedy or exchange hereunder will be remedied or exchanged by the authorized radio dealer or wholesaler without charge to the owner.

This warranty is in lieu of all other warranties expressed or implied and no representative or person is authorized to assume for us any other liability in connection with the sale of our radio products."

the hallicrafters co.

092-DH555



Figure 1. View of the Model HA-6 Transverter.

SECTION I INTRODUCTION

1-1. DESCRIPTION.

The Model HA-6 Six-Meter Transverter is a two-way converter which is designed to be used in conjunction with a 28-MC to 30-MC transmitter/exciter and receiver to convert the ten-meter signals to the six-meter band.

The transverter will handle any mode of transmission (CW, SSB, AM, FM, PM, FSK, etc.) supplied by the exciter, since it is basically a linear system and does not change the signal characteristics. The Model HA-6 Six-Meter Transverter may be used in a simple arrangement with an exciter, receiver, six-meter antenna, and power supply, or it may be used as part of a complete system. This system would include the Model HA-2 Two-Meter Transverter and could include automatic switching between the two-meter and six-meter transverters and the present ten-meter station. The cabling diagram, figure 3, gives the details of equipment necessary to perform the automatic switching function.

Two type CR-23/U crystals are supplied to convert the 28-MC to 30-MC output from the exciter to frequency segments of 50 MC to 52 MC, and 52 MC to 54 MC; the same crystals also convert the received frequency segments of

50 MC to 52 MC, and 52 MC to 54 MC into 28 MC to 30 MC for the receiver. Exciters used with the transverter must have excitation control, such as an RF output level adjustment or other means, to properly set the carrier level required for AM operation.

The transverter receives power from an external supply. The Model P-26 Power Supply has been designed as a companion unit to the Model HA-6 Transverter; however, other power supplies, supplying the required voltage, may be used. One Model P-26 Power Supply will handle both a Model HA-6 and a Model HA-2 (Two-Meter Transverter), and is so interlocked as to prevent the HA-6 and HA-2 from operating at the same time.

The transverter is designed to work with a 28-MC to 30-MC station receiver having a 50-ohm antenna input and provides a 50-ohm coaxial termination for a 28-MC to 30-MC station transmitter/exciter. There are two inputs provided on the rear panel for connection to the exciter. The HIGH LEVEL INPUT connector is used with an exciter having 25 watts PEP output capability (50 watts when both the HA-2 and HA-6 are connected together). A LOW LEVEL INPUT connector is provided for those exciters with a 0.5-watt PEP output capability (1 watt when both units are connected).

1-2. TVI SUPPRESSION.

The Model HA-6 Six-Meter Transverter has been designed and constructed to suppress spurious signals that may cause television interference (TVI). The TVI problem was given full consideration in the design of every circuit, as well as in the selection and layout of parts. The equipment has been carefully shielded and connector lead bypassing has been provided throughout. Components were specifically selected to avoid undesired resonances and arranged to prevent parasitic oscillation.

The transverter, as received from the factory, has had every advantage of Hallicrafters' engineering experience to minimize television

interference. There are, however, some types of TVI that cannot be prevented within the equipment itself. For example, when a television receiver is located in the immediate vicinity of the transverter, it is entirely possible that a fundamental signal will reach the input grid of the receiver with sufficient strength to cause a small amount of interference. In this case, it will be necessary to install a filter or trap at the television receiver to attenuate the transmitted signal. If the interfering signal does not enter the television receiver through the antenna, special shielding or filters on the TV receiver may be necessary. For a more complete discussion of measures that may be used to handle these special television interference problems, refer to the ARRL HANDBOOK.

SECTION II SPECIFICATIONS

POWER SOURCE	Model P-26	105 volts to 125 volts, 60 cycles, AC; 290 watts maximum.
MODE OF EMISSION		Determined by exciter and receiver used.
FREQUENCY COVERAGE		50 MC to 54 MC.
RECEIVER/EXCITER FREQUENCY RANGE REQUIRED		28 MC to 30 MC.
TERMINATING IMPEDANCE (All connectors)		50 ohms.
RECEIVER CONVERTER PERFORMANCE:		
Noise Figure		2 DB to 5 DB.
Sensitivity		1.5 μ V/10 DB S/N (Limit).
TRANSMITTER CONVERTER PERFORMANCE:		
POWER OUTPUT		
SSB (PEP), CW, FSK, FM, PM, etc.		60 watts.
AM (carrier)		15 watts.
EXCITATION REQUIRED		
High Level Input		25 watts maximum.
Low Level Input		0.5 watts approximately.
DIMENSIONS		8 inches high by 9-7/8 inches deep by 17 inches wide.
SHIPPING WEIGHT		22.5 pounds.

SECTION III

INSTALLATION

3-1. UNPACKING.

After unpacking the transverter, examine it carefully for any possible damage that may have occurred during transit. Should any sign of damage be apparent, immediately file a claim with the carrier stating the extent of damage. Check all shipping labels and tags for any special instructions before removing or destroying them.

3-2. LOCATION.

Even though the Model HA-6 Transverter is provided with a built-in cooling fan, excessively warm locations, such as those near radiators and heating vents, should be avoided. The unit should be placed in a location that provides adequate space around it (a minimum of three inches on each side) to permit free circulation of clean air through the cabinet openings. Also, sufficient clearance should be allowed at the rear of the unit to facilitate connecting the Model HA-6 to associated equipment.

3-3. POWER SOURCE.

The Model HA-6 Six-Meter Transverter is designed to operate from a Model P-26 or equivalent external power supply. The Model P-26 Power Supply operates from a 105-volt to 125-volt, 60-cycle, AC power source; power consumption

of the equipment will not exceed 290 watts. If a power supply other than the Model P-26 is used as the power source for the transverter, the power supply must meet the requirements specified in the data concerning power supply circuitry, paragraph 3-6.

NOTE

The power outlet must furnish AC (alternating current). If in doubt about the power source, contact the local power company prior to inserting the power cord in a power outlet. Plugging the cord into the wrong power source may cause extensive damage to the power supply unit, requiring costly repairs.

3-4. SINGLE-UNIT INSTALLATION.

The following procedure covers the installation of the Model HA-6 Transverter and the Model P-26 Power Supply.

1. Interconnect the power supply and the transverter by connecting the high voltage cable (HV connectors) and the multi-conductor cable (POWER connectors). The jumper plug supplied with the power supply must be inserted in the unused 11-pin POWER socket of the power supply.

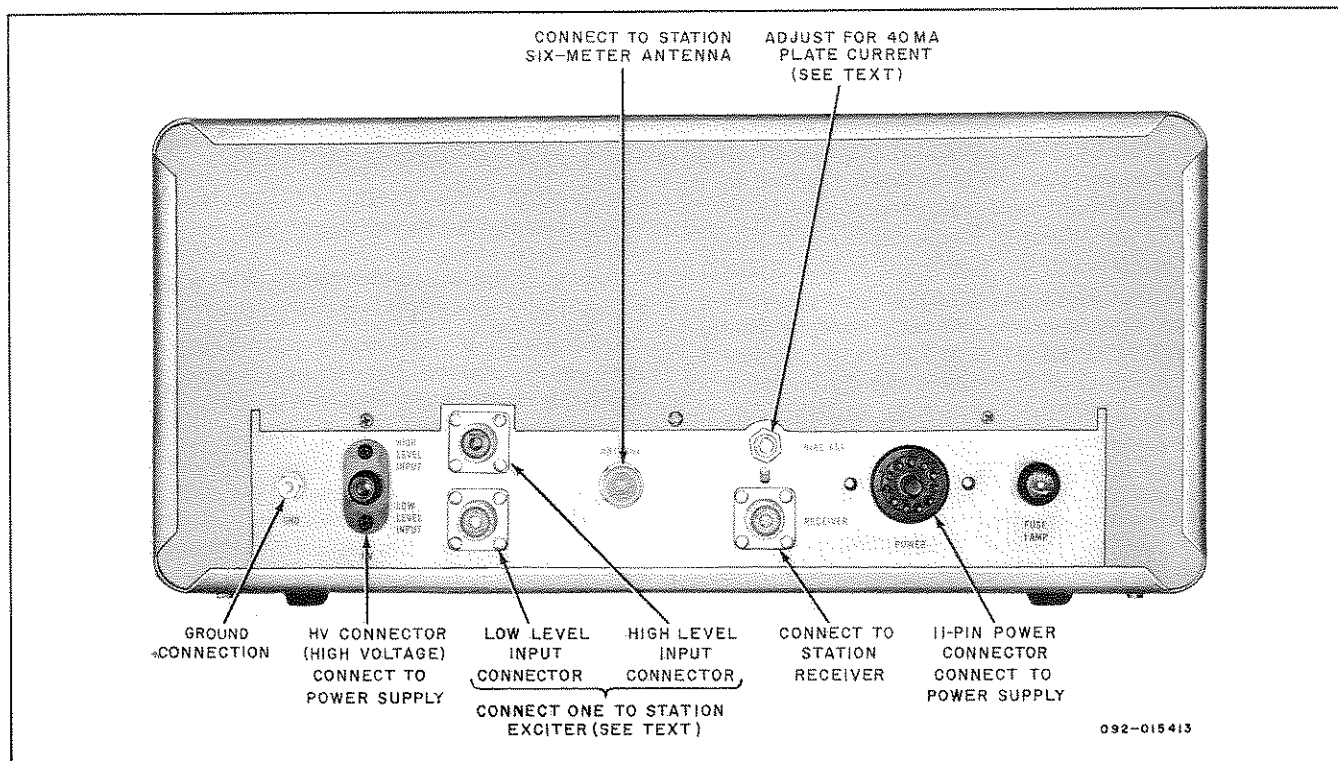

Figure 2. Rear View of Transverter, Showing Connectors.

CAUTION

Do not connect the line cord to a source of power until all other wiring is completed and checked.

2. A single black No. 22 stranded wire, connected to pin 2 of the 11-pin female power cable connector, is supplied attached to the power cable. Run this control wire to the station exciter and connect it to an unused control switch terminal or VOX relay contact which will connect this wire and its circuit to ground during transmission and open it during reception. The relay contact is preferred so that VOX operation, if normally available, can be used for VHF operation also.

NOTE

Do not connect to a relay or switch contact already carrying other exciter circuits. The transverter relay is energized by a 12-volt DC source within the transverter, and grounding the control wire closes the relay during transmission.

3. Interconnect the station receiver's antenna input and the transverter RECEIVER output connectors. Use 50-ohm coaxial cable to insure a well-shielded circuit.

4. Interconnect the antenna output of the station transmitter/exciter with either the HIGH LEVEL INPUT or the LOW LEVEL INPUT connector, depending upon the output power capability of the transmitter/exciter. A 25-watt to 100-watt exciter should be connected to the HIGH LEVEL INPUT. It may be operated without the use of an attenuator pad in the line. A low-level exciter in the one-watt class must be connected to the LOW LEVEL INPUT. An exciter in the 10-watt to 20-watt class should be first connected to the HIGH LEVEL INPUT to determine whether it is capable of driving the transverter. If not, connect the exciter into the LOW LEVEL INPUT with a suitable 50-ohm attenuator to reduce the drive level reaching the transverter. One-half watt to one watt PEP is sufficient to drive the transverter at the LOW LEVEL INPUT. Use 50-ohm coaxial cable to maintain a low SWR.

5. Connect the 50-ohm transmission line from the six-meter antenna to the ANTENNA connector on the transverter.

The Model HA-6 Six-Meter Transverter is now ready for operation and will convert all modes of transmission provided by the ten-meter station exciter unit. Also, VOX operation, if normally used at the station, will continue to function as before.

3-5. TWO-UNIT INSTALLATION.

The following procedure covers the complete six-meter and two-meter installation using transverter Models HA-6 and HA-2, and the Model P-26 Power Supply. The installation shown in figure 3 provides automatic changeover from low frequency station operation to VHF operation. The VHF band to be used is selected by turning on the particular transverter for that band. Turning on both transverters merely disables the entire operation until one of the units is turned off.

1. Interconnect the power supply and the transverters by connecting the high voltage cables (HV connectors) and the multi-conductor cables (POWER connectors). The jumper plug supplied with the power supply is removed to make room for the second power cable. Keep the jumper plug near at hand in case single-unit operation is desired. The jumper plug completes the switching and bias supply circuits so that a single transverter can be operated from the power supply.

2. Run the two black insulated No. 22 stranded wires, connected to pin 2 of each of the multi-conductor cables, over to the station exciter and connect them to an unused control switch terminal or VOX relay contact which will connect these wires to ground during transmission and open them during reception. The relay contact is preferred so that VOX operation (if normally available) can be used for VHF operation too.

NOTE

Do not connect to a relay or switch contact already carrying other exciter circuits. The transverter relays are energized by a 12-volt DC source within the transverter; grounding the control wire during transmission closes the relay of the transverter which has been turned on.

3. Interconnect the station receiver's antenna input and the transverter RECEIVER output connectors. If automatic changeover from low frequency station operation to VHF operation is desired, use relay RY3 as shown in the cabling diagram. Note that this relay has a 117-VAC coil and is supplied along with relay RY1 by the RELAY output on the power supply, so that both relays will be energized when either transverter is turned on. Refer to the cable diagram for coaxial cable and connector type details. The "Tee" connector can be installed at either transverter, depending upon the requirements of the particular station layout.

4. Interconnect the antenna output of the station transmitter/exciter with either the HIGH LEVEL INPUT or the LOW LEVEL INPUT connectors, depending upon the output power capa-

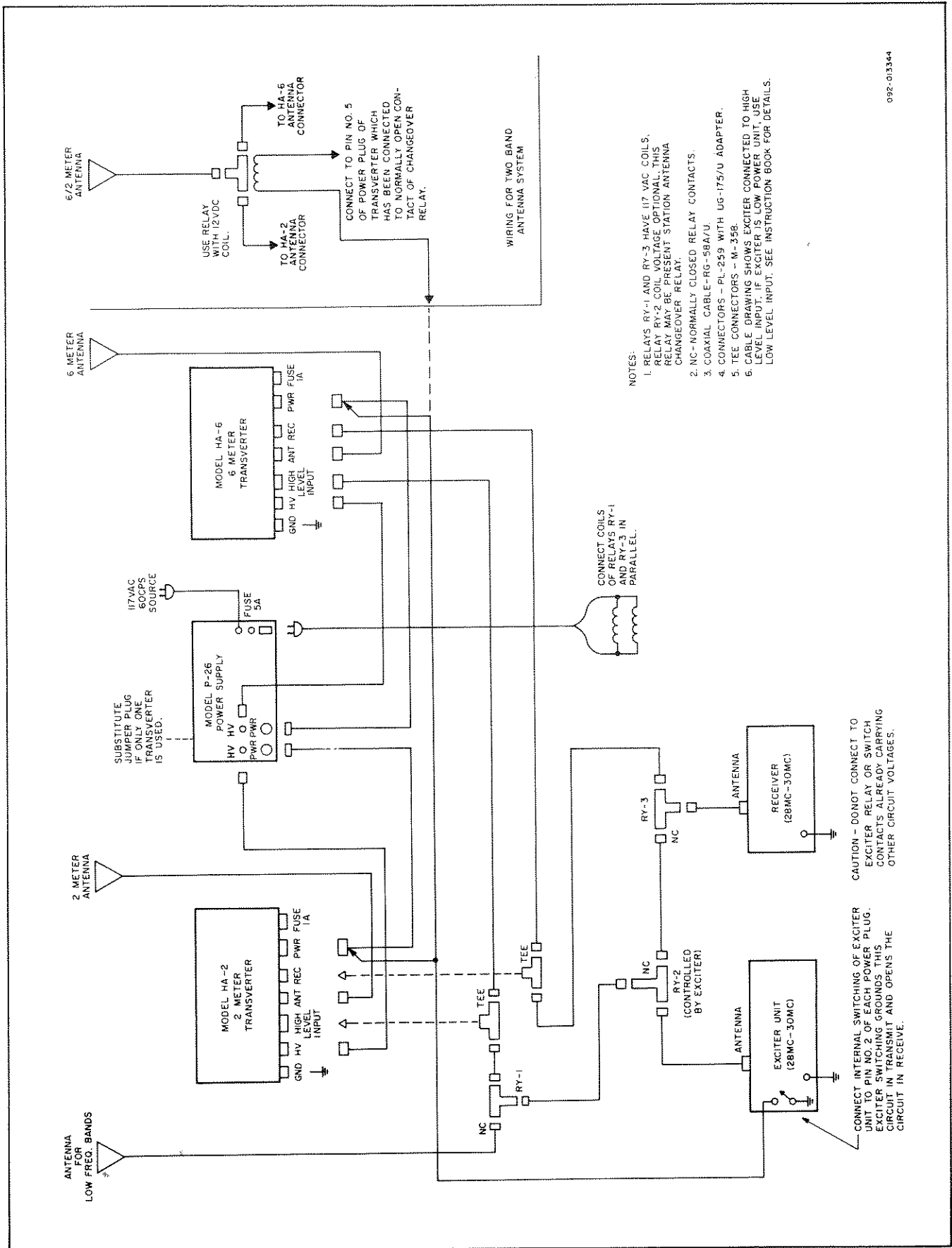

092-013344

Figure 3. Interconnecting Cabling Diagram.

bility of the transmitter/exciter. A 50-watt to 100-watt exciter should be connected to the HIGH LEVEL INPUT of the transverters. A low level exciter in the one-watt to two-watt class must be connected to the LOW LEVEL INPUT. Exciters in the ten-watt to twenty-watt class, connected to the HIGH LEVEL INPUT, will not be capable of driving the two-unit installation. Therefore, these exciters should be connected to the LOW LEVEL INPUT connectors through a suitable attenuator to drop the PEP output to approximately the one-watt to two-watt level which is required by two transverters connected in parallel. The attenuator should be installed between relay RY1 and the "Tee" connector shown in the cabling diagram. Here again, if the automatic changeover feature is desired, relay RY1 is required in addition to RY3, as shown on the diagram. If the exciter is used extensively for VHF operation, then the relays RY1, RY2, and RY3 can be dispensed with and the two transverter units, with their inputs connected in parallel, are connected directly to the exciter. The parallel connection presents a 2/1 SWR to a 50-ohm exciter output and requires approximately 50 watts PEP at the HIGH LEVEL INPUT connector and approximately one watt to two watts PEP at the LOW LEVEL INPUT connector. Again, the location of the "Tee" connector is determined by the station layout.

5. If individual antennas are used on each of the bands, connect the transmission lines to the respective ANTENNA connectors on the transverters. Installations using a single two-band antenna system can have automatic relay switching, as shown in the cable diagram. Note that the an-

tenna selector relay for this system has a 12-volt DC coil and is energized by the 12-volt supply in the transverter. In order to obtain the proper switching of this relay, particular attention should be directed to the wiring conditions specified in the cable diagram. When properly wired, the relay will switch the antenna to the transverter which has been turned on by the operator.

3-6. POWER SUPPLY REQUIREMENTS.

If a power supply other than the Model P-26 is to be used, it must meet the following requirements:

1. 750 volts DC at 40 MA idle plate current. Approximately 700 volts minimum supply voltage at 150 MA plate current.

2. Low B+ supply of 250 volts at a receive load of 40 MA and 260 volts DC at transmit load of 125 MA respectively. Check figure 15 and note the center tap resistor used in the Model P-26 Power Supply to accomplish this.

3. Bias supply of minus 60 volts in transmit mode with 6800-ohm transverter loading. If both the HA-2 and HA-6 are to be operated from this supply, bias supply must handle a 3400-ohm load and contain a jumper plug arrangement similar to that used with the Model P-26 supply.

A schematic diagram of the Model P-26 Power Supply is contained in figure 15 of this manual.

SECTION IV

CONTROLS AND OPERATION

4-1. GENERAL.

The Model HA-6 Six-Meter Transverter, in the transmit function, accepts 10-meter signals from a transmitter/exciter, converts these signals to six-meter signals, amplifies them, and then feeds the signals to a six-meter antenna for transmission. In the receive function, the Model HA-6 accepts six-meter signals from an antenna, amplifies and converts these signals to 10-meter signals, and applies them to a receiver.

Before turning the transverter on, be certain that the control switch on the transmitter/exciter or on the station control (if used) is in the standby or receive position.

4-2. OPERATING PROCEDURE.

Turn the POWER switch on the transverter to ON. Allow 10 minutes to 15 minutes for the

transverter to warm up before placing the transmitter/exciter in the transmit mode. During this time, the transverter can be checked out in the receive function and, if the two-meter transverter is also used, the interlock function of the power supply can be checked.

To check the interlock function, turn the POWER switch on the unused transverter to ON. If the interlock is functioning properly, power will be removed from both units.

To check the transverter in the receive mode, tune the station receiver as for ten-meter reception. Note that the receiver tunes only one-half of the six-meter band at a time. The RANGE switch must be used to cover the entire six-meter band. The frequency of the station being received may be determined by referring to figure 5.

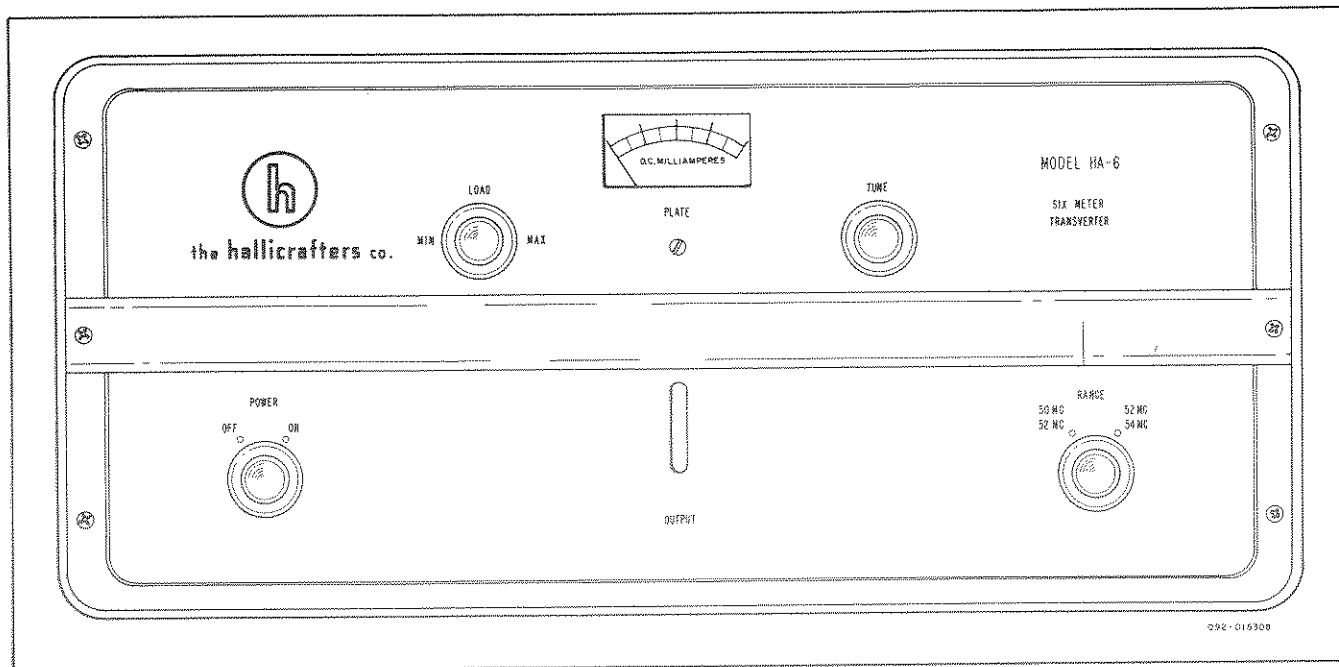

Figure 4. Front Panel of Transverter.

After the transverter has warmed up, turn the transmitter/exciter to transmit, but do not apply excitation to the transverter. Note the idling plate current on the PLATE current meter on the front panel of the transverter. If the idling plate current does not show 40 milliamperes, adjust the BIAS ADJ. control on the rear apron of the transverter to obtain this idling plate current.

Set the RANGE switch to the desired segment (50 MC to 52 MC, or 52 MC to 54 MC).

4-3. TUNING AND LOADING (CW or SSB Operation).

1. Set the LOAD control on the transverter to approximately mid-position.

2. Set the station transmitter/exciter for CW operation. Adjust the carrier level for approximately 100 milliamperes of plate current on the PLATE meter of the transverter and immediately adjust the TUNE control for maximum RF output, as shown on the OUTPUT indicator. Maximum output is indicated when the gap between the two shafts of light on the indicator is the narrowest.

3. Adjust the output of the exciter to maintain a transverter plate current of 150 to 180 milliamperes while making the loading adjustment. The final amplifier tube is operating at its peak dissipation at this time, so perform the loading adjustment rapidly. Adjust the LOAD and TUNE controls for maximum output as indicated by the OUTPUT indicator. As the operating frequency is changed, it will be found necessary to touch up the TUNE control only. The LOAD control will generally not change setting.

4. Set the drive level of the station exciter to obtain a transverter plate current reading of 150 milliamperes for CW, FM, FSK teletype, and similar modes of transmission.

5. Switch the exciter to SSB and check single-sideband transmission. Advance the microphone gain control on the exciter and watch the OUTPUT indicator while talking into the microphone. The drive level is approximately correct when the OUTPUT indicator gap closes or shows signs of saturation levels on voice peaks and the plate current swings to approximately mid-scale.

4-4. TUNING AND LOADING (AM Operation).

1. Perform steps 1, 2, and 3 as outlined in paragraph 4-3 for tuning and loading for CW operation.

2. The station exciter and transverter are now tuned and loaded at the maximum plate current level. To set up the required carrier level, slowly advance the carrier level control of the exciter, starting from a low level, until the OUTPUT indicator of the transverter shows evidence of saturation. This will generally occur when the plate current of the transverter reaches approximately 150 to 180 milliamperes. If the station exciter has an RF voltmeter in its output circuit, reduce the carrier level to 1/2 this voltage (reduce it 6 DB if a decibel scale is provided). This sets up the maximum permissible carrier level that the transverter output tube can accept and still handle modulation peaks without flat-topping. If the exciter does not have an RF output metering system, the carrier injection can be

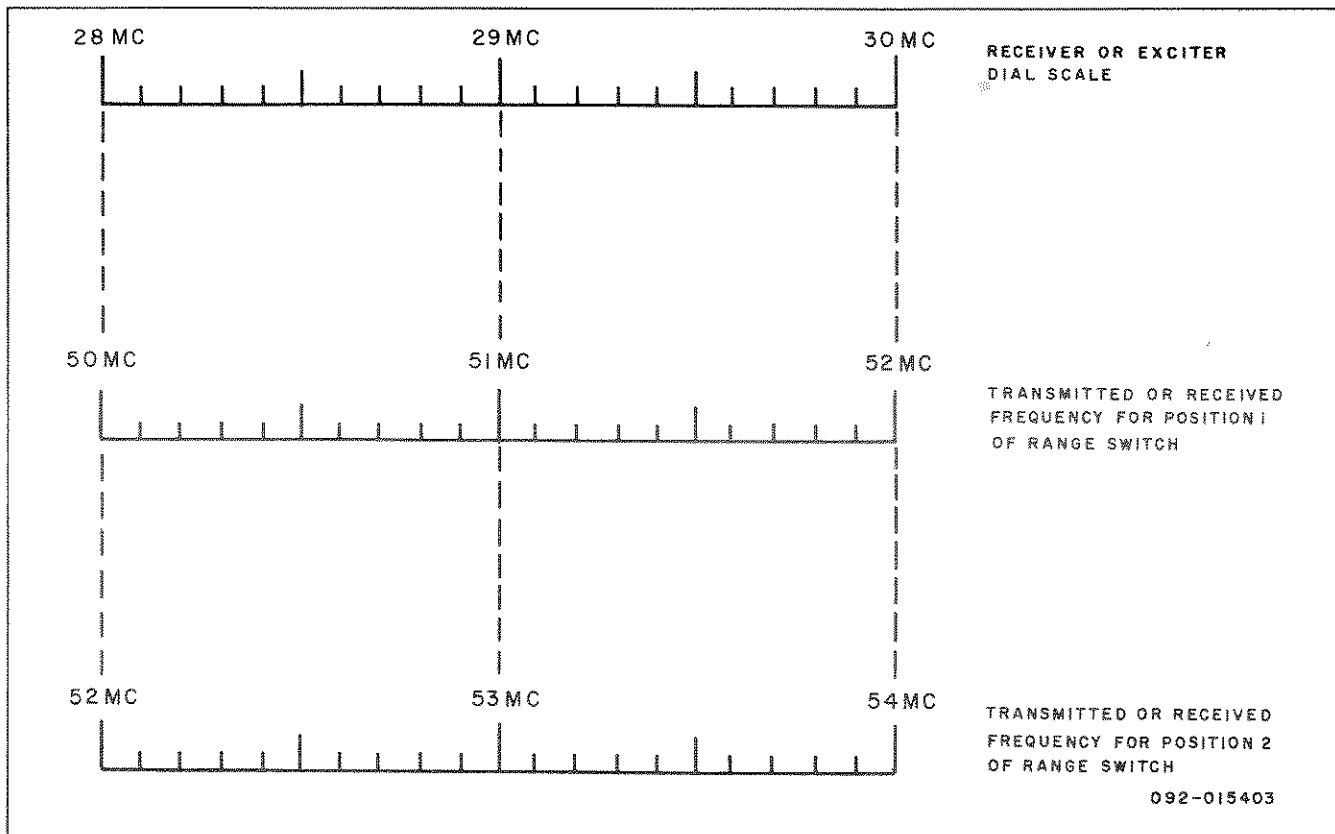

Figure 5. Frequency Conversion (Dial Scale Interpolation).

set for approximately 110 milliamperes of plate current on the transverter. Set the microphone gain for 100% modulation by watching the OUTPUT indicator and final plate current. Over-modulation will be evident when the plate current of the transverter begins to shift, in step with the voice peaks, from its unmodulated carrier reading.

4-5. MATCHING RECEIVER AND TRANSMITTER FREQUENCY.

Many times the operator finds it desirable to transmit and receive on the same frequency. The transverter uses the same heterodyning oscillator for both transmit and receive; therefore, it is merely necessary to zero the station receiver to the station exciter on the ten-meter

band in the usual manner. Normally, the local radiation from the exciter reaches the receiver in sufficient strength to produce the desired beat. If not, a wire connected to the receiver antenna and placed near the station exciter unit will increase the coupling, but also may increase the ten-meter band feed-through when receiving.

4-6. SIDEBAND SWITCHING ON SIX METERS.

The upper and lower sideband positions on the six-meter band remain as they were for the ten-meter band. The heterodyning frequency used in the transverter falls below the six-meter band; therefore, the mixing action involves the addition of the frequencies involved and the relative position of the sidebands does not reverse.

SECTION V

THEORY OF OPERATION

5-1. GENERAL.

The Model HA-6 Six-Meter Transverter is basically a heterodyning system complete with a linear power amplifier for transmission, and a low-noise front end for reception. The conversion takes place between the ten-meter band and the six-meter band. Since the ten-meter band is only two megacycles wide, the six-meter band must be covered in two steps, as it is four megacycles

wide. This is accomplished by changing the heterodyne oscillator frequency. By using a common heterodyne oscillator for transmission and reception, the six-meter frequency will be exactly the same for transmitter and receiver if the two units are matched for frequency on the ten-meter band. The transverter can handle any mode of transmission or reception normally handled by the station's ten-meter equipment, since it is for all practical purposes a linear system.

5-2. HETERODYNING OSCILLATOR.

The heterodyning signal is supplied by a Butler-type crystal oscillator and amplifier (tubes V6 and V7). Inasmuch as a minimum of two heterodyne frequencies are required to cover the six-meter band, the crystal oscillator and amplifier are bandpass-coupled and a total of two crystals can be accommodated for range switching. For 28-MC to 30-MC receivers and transmitters, the two heterodyning frequencies will be 22 MC and 24 MC and the crystal frequencies used are 22,000 KC and 24,000 KC. The oscillator uses CR-23/U type crystals which operate on the third mode and at series resonance.

5-3. RECEIVE FUNCTION.

For the receive function, the changeover relay is unenergized. The six-meter signal at the antenna is thus coupled through transformer L1 to the type 6CW4 low-noise, RF amplifier. The output of the RF amplifier is bandpass coupled to the type 6BZ6 mixer which, in turn, is bandpass coupled to the station receiver so that tuning of the transverter unit by the operator is not required. The coupling unit in the plate of the mixer is designed to match a receiver with a 50-ohm antenna input.

During the receive function, the relay disconnects the 250-volt supply from the transmitter mixer and amplifier stages and also switches in resistance at the center tap of the plate supply transformer to account for the load change in the receive function.

5-4. TRANSMIT FUNCTION.

For the transmit function, the changeover relay is energized. Since the DC source for the relay is supplied by the transverter, only external switching of the single coil return lead is required to control the unit.

For the transmit function, the relay transfers the 250-volt source from the receiver converter mixer and amplifier stages to the transmitter converter mixer and amplifier stages. At the same time, the relay also grounds the center tap of the plate transformer in the power supply to accommodate the change in load.

The ten-meter signal from the station exciter is fed into the transverter at either of two inputs, depending upon the output power capabilities of the exciter. The HIGH LEVEL INPUT provides a 50-ohm, 25-watt termination and requires approximately 25 watts of signal to drive the transverter to full output. The LOW LEVEL INPUT provides approximately a 50-ohm termination but requires only one-half watt of drive.

Before reaching the 12BY7A mixer tube, the exciter signal must pass through a low-pass filter to avoid spurious signals caused by its harmonic content.

At the 12BY7A mixer, the 28-MC to 30-MC signal mixes with the same two heterodyning oscillator signals used for reception. The 50-MC

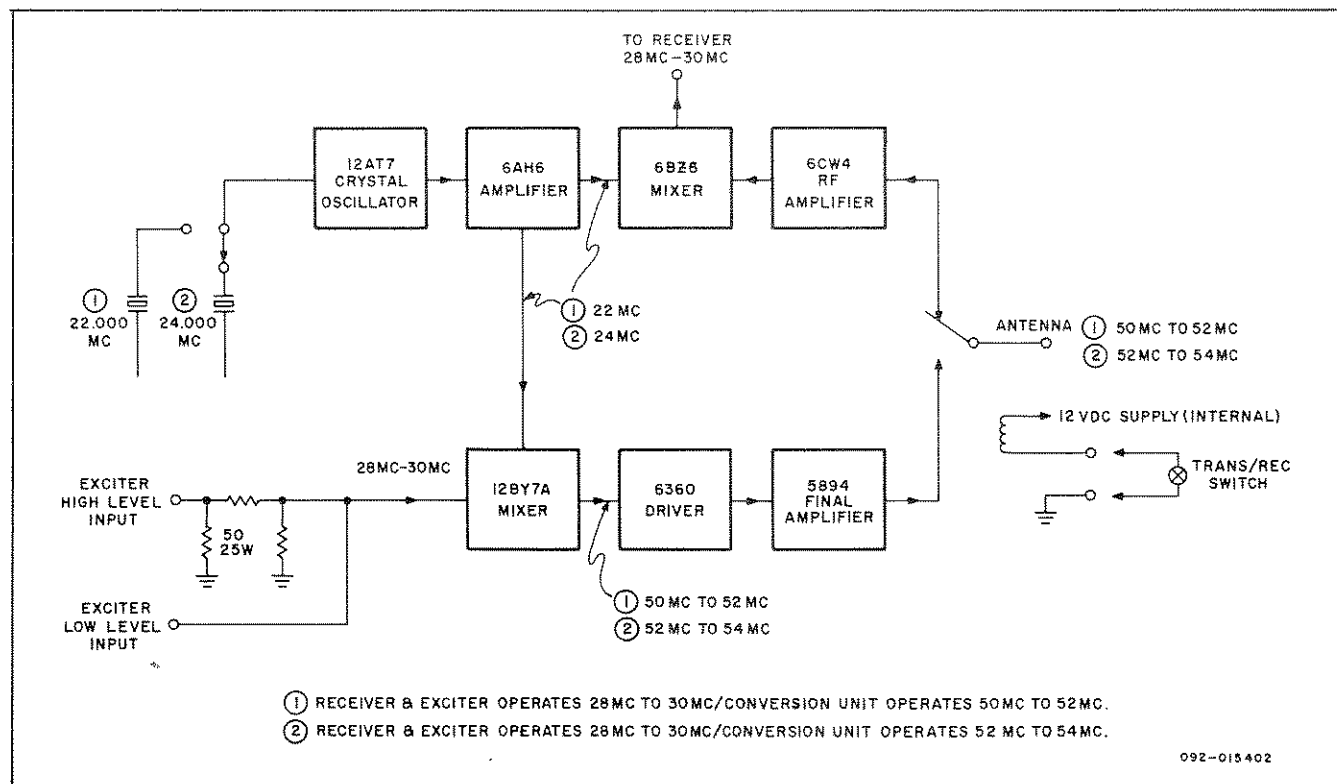

Figure 6. Block Diagram of Transverter.

to 52-MC signal is produced with the 22-MC oscillator signal, and the 52-MC to 54-MC signal is produced with the 24-MC oscillator signal.

From the plate of the mixer through the type 6360 driver stage to the grids of the final amplifier, the tuned circuits are bandpass coupled so that operator tuning of these stages is avoided. Therefore, the only tuning required is at the plate of the final amplifier and the series resonant loading control. The driver and final amplifier stages are linear amplifiers operating class A and AB₁, respectively. Since screen grid tubes cannot operate safely without a load, a fixed link is provided to insure that a good percentage of the load

is coupled to the tube at all times. The series resonant link adjustment permits additional loading for optimum power transfer to the antenna transmission line through the coaxial relay.

To help the operator establish optimum loading, a sample of the transmission line RF voltage is taken at the output of the link and rectified. The rectified DC voltage is then applied to the grid of the 6FG6 output indicator where it is amplified and used to drive a fluorescent display electrode. By adjusting both the TUNE and LOAD controls for maximum RF voltage at the maximum output level capability, the operator is assured of best linearity at all drive levels, including PEP.

SECTION VI

SERVICE DATA

6-1. TUBE AND LAMP REPLACEMENT.

To gain access to the tubes and dial lamps, refer to paragraph 6-2, CHASSIS REMOVAL. The tube and lamp locations are shown in figure 9. Replace the meter lamp with a type 47 bayonet base lamp.

6-2. CHASSIS REMOVAL.

The Model HA-6 Transverter cabinet was designed to provide RF shielding. For this reason, replace all hardware when returning the chassis unit to the case. To remove the chassis from the cabinet: 1) remove the three phillips-head screws at the cabinet rear directly above the connectors, 2) remove the three screws and external-tooth lockwashers from the bottom of the cabinet, 3) remove the six phillips-head screws from the front panel, three on each side (the trim strip comes off when the center screws are removed), and 4) slide the chassis forward out of the cabinet.

6-3. VOLTAGE AND RESISTANCE MEASUREMENTS.

The voltages and resistances to ground on the pins of each tube within the Model HA-6 Transverter are contained in the Voltage and Resistance Charts, figures 7 and 8. The conditions of operation at the time these readings were made are specified on the charts.

6-4. SERVICE AND OPERATING QUESTIONS.

For further information regarding operation or servicing of the transverter, contact the Hallicrafters' dealer from whom the equipment was purchased. The Hallicrafters Company maintains an extensive system of Authorized Service Centers where any required service will be performed promptly and efficiently at a nominal charge. All Hallicrafters Authorized Service Centers display the sign shown below. For the location of the one nearest you, consult your local telephone directory.

Do not make any service shipments to the factory unless instructed to do so by letter. The Hallicrafters Company will not accept the responsibility for unauthorized shipments.

The Hallicrafters Company reserves the privilege of making revisions in current production of equipment and assumes no obligation to incorporate these revisions in earlier models.



SECTION VII

ALIGNMENT

7-1. GENERAL.

The Model HA-6 Six-Meter Transverter has been carefully aligned at the factory and with normal usage will not require major realign-

ment unless extensive circuit repair is required which would upset the resonant circuits. Alignment should not be attempted until all other possible causes of faulty operation have been investigated.

CAUTION

A POTENTIAL OF 750 VOLTS DC EXISTS ON THE PLATE CIRCUIT OF THE FINAL AMPLIFIER TUBE WHEN THE TRANSVERTER IS TURNED ON. EXERCISE CAUTION WHEN MAKING SOCKET VOLTAGE MEASUREMENTS.

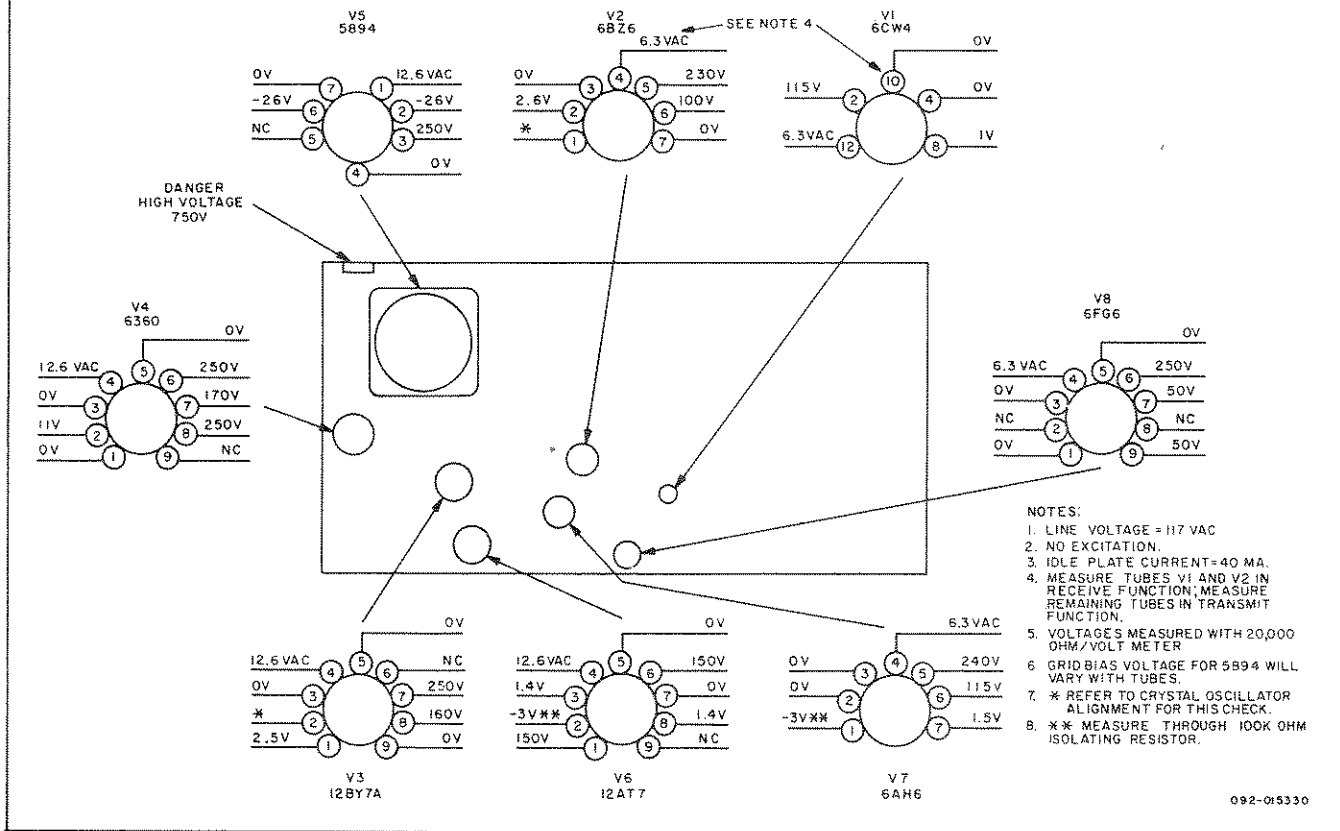

Figure 7. Voltage Chart.

Alignment should only be performed by persons having access to and familiarity with the use of sweep equipment. Refer to figures 9, 10, and 12 for the location of all alignment adjustments.

7-2. EQUIPMENT REQUIRED.

The following equipment is required when aligning the Model HA-6 Transverter:

1. Dummy load - 50 ohms non-inductive to 60 MC, rated at 100 watts.
2. Vacuum tube voltmeter (VTVM); Hewlett-Packard Model 410 or equal, having an RF probe good to 60 MC.
3. Oscilloscope (10 millivolt/CM vertical deflection sensitivity).
4. Sweep frequency signal generator with a 50-ohm output termination capable of sweeping the frequency range of 18 MC to 78 MC; Jerrold Model 601 or equivalent.

5. 50-ohm calibrated attenuator with 1-DB step position; Kay Electric Company type or equivalent.

6. Signal generator with a 50-ohm termination, tunable through 28 MC to 32 MC and 50 MC to 60 MC bands; Hewlett-Packard Model 608 or equivalent.

7-3. BIAS ADJUSTMENT.

The bias adjustment control is located on the rear chassis apron of the transverter (see figure 2). The control is set for 40 MA plate current after placing the unit in the transmit condition (no signal applied). This adjustment will normally hold over long periods of time. A small temporary change in idling plate current may show after a heavy plate current load during tuneup but generally will settle back after the tube cools off.

7-4. CRYSTAL OSCILLATOR ALIGNMENT.

CHECKING CRYSTAL OSCILLATOR INJECTION. -Before altering the alignment adjustments for the crystal oscillator, check as follows to determine whether realignment is required:

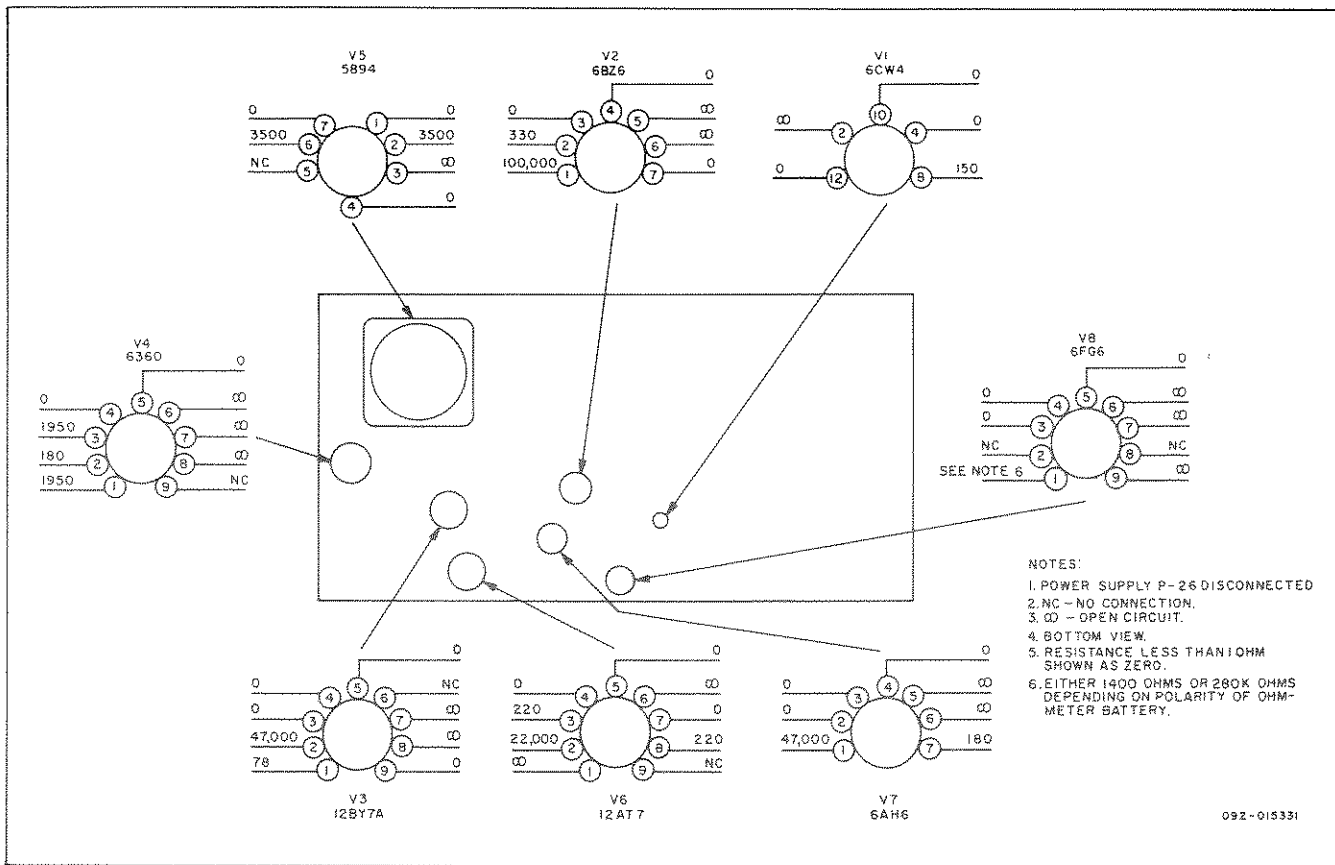

Figure 8. Resistance Chart.

1. Remove the type 5894 tube and disconnect the HV cable between the transverter and the power supply. For convenience, the transverter may be operated outside the cabinet for this check. The type 5894 tube and HV cable are removed for safety reasons, both for the operator and the tube. Removing the high voltage alone would damage the screen of the tube.

2. Turn on the transverter and allow approximately 15 minutes for equipment to stabilize.

3. Place the transverter in transmit condition by grounding the relay coil return wire (pin 2 of POWER plug).

4. With a 100K-ohm isolating resistor connected to the probe of a high impedance DC voltmeter, check the rectified grid voltage at the grid (pin 2) of the 12BY7A mixer tube. If the injection voltage is equal for both RANGE switch positions and is approximately minus two to four volts, no alignment adjustments of the crystal section will be required. If a VTVM with a low capacity RF probe is available, a four to six volt RMS voltage should appear at the grid of the 12BY7A mixer. If the injection voltages are equal within approximately 0.5 volts, consider the alignment complete.

ALIGNMENT PROCEDURE FOR CRYSTAL OSCILLATOR STAGE. -If the check outlined above indicates that alignment is necessary, proceed as follows:

1. As outlined above, the 5894 tube and HV cable are removed for this adjustment. For convenience, the transverter may be operated outside the cabinet. The 5894 tube and HV cable are removed for safety reasons, both for the operator and the tube. Removing the high voltage alone would damage the screen of the tube.

2. Before attempting to realign the band-pass circuit between the 6AH6 crystal amplifier tube and the 12BY7A mixer tube, check the setting of coil L12. Place the transverter in the transmit condition (ground relay return wire at pin 2 of POWER socket) and read the rectified grid voltage at the 12BY7A mixer tube through the 100K-ohm isolating resistor. To determine the correct setting for coil L12, turn the core adjustment counterclockwise until the oscillator just starts as the RANGE switch is switched to position 1. Note the position of the slot in the adjustment screw. Now turn the core adjustment clockwise until the oscillator just starts as the RANGE switch is switched into position 2. There will normally be one to three turns of the core difference between the two settings. Set the core position midway between these two settings. If

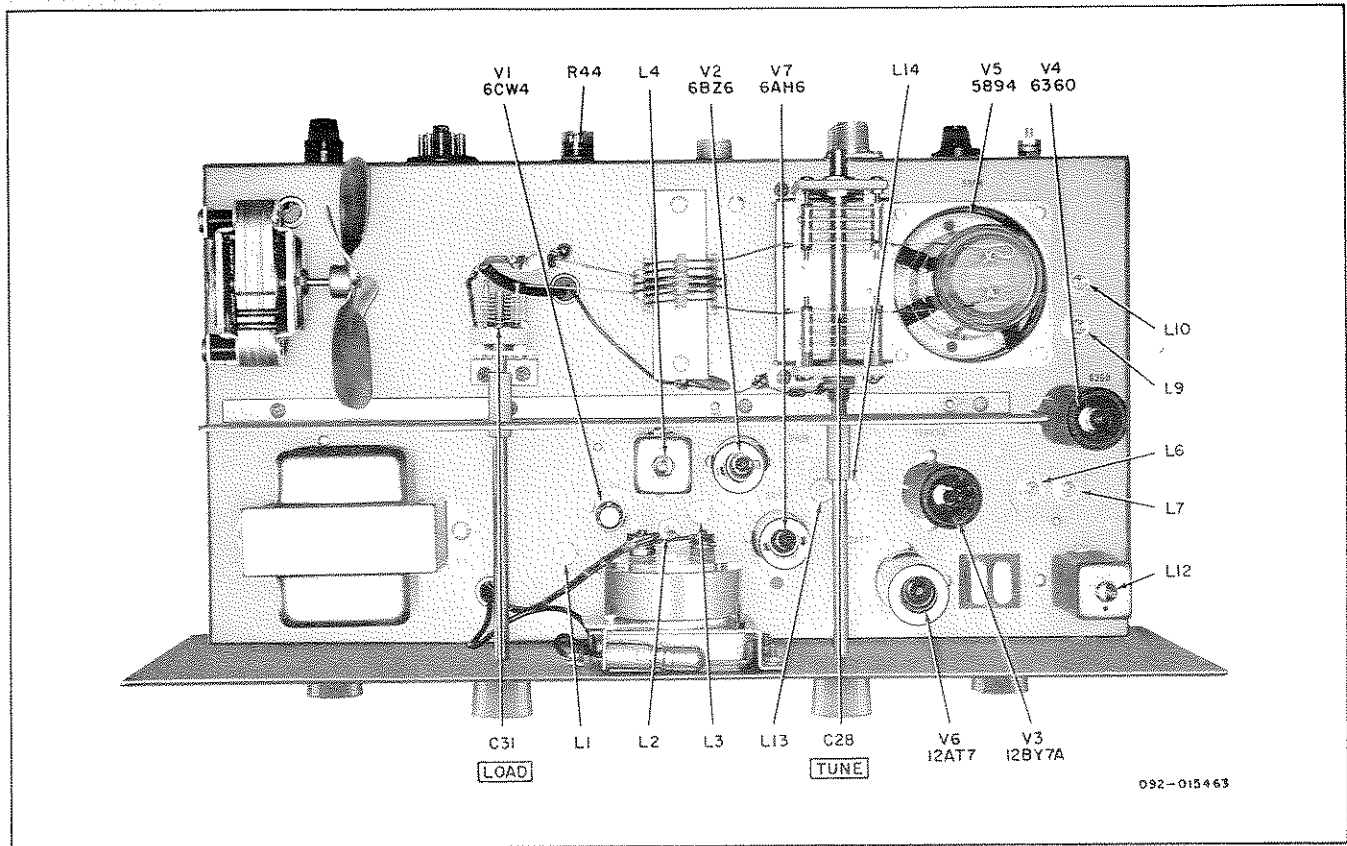

Figure 9. Top View of Transverter Chassis.

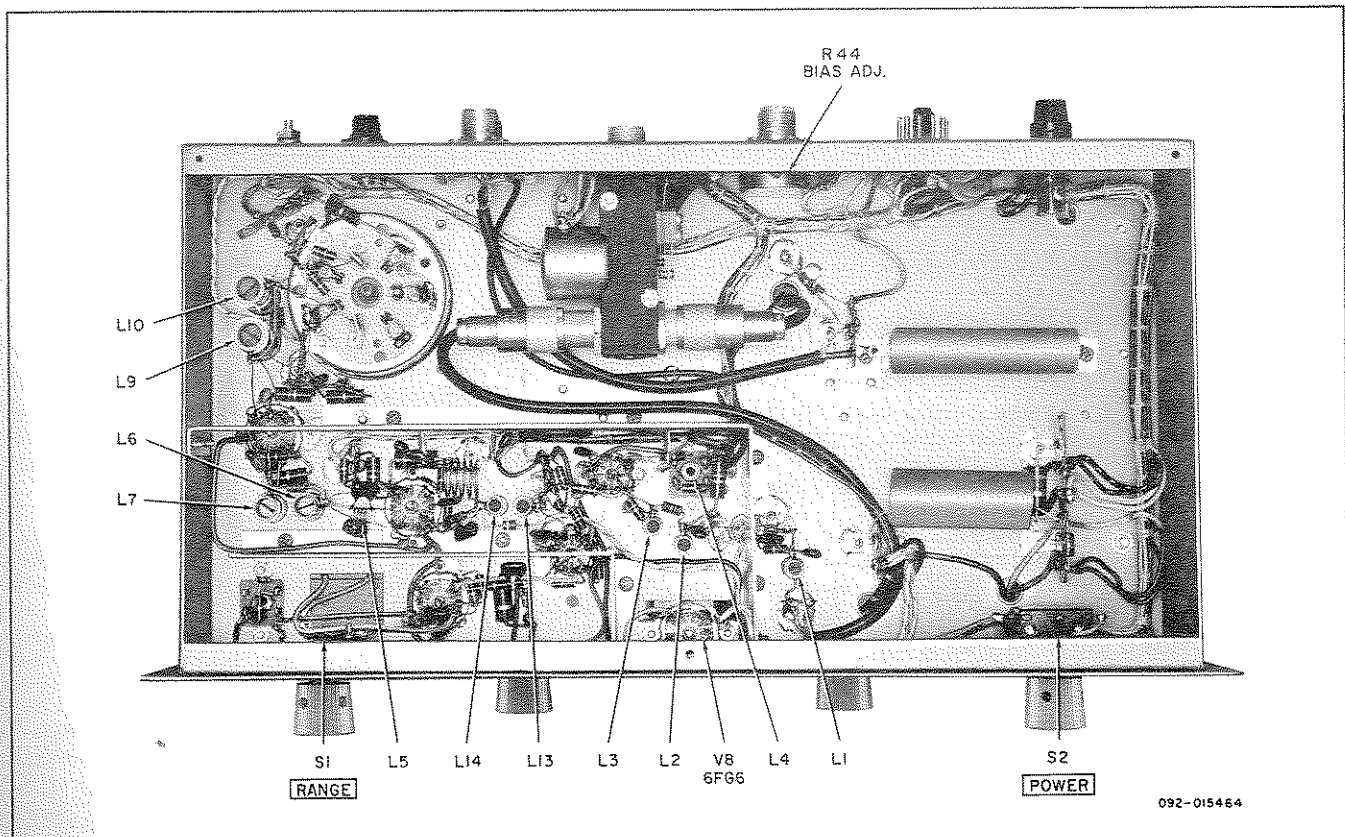

Figure 10. Bottom View of Transverter Chassis.

the rectified grid voltage is now equal within approximately 1/2 volt between the two range positions and approximately minus two to minus four volts of injection, the alignment is satisfactory. Here again, a VTVM check is more desirable. The AC voltage should be around four to six volts RMS and equal within 0.5 volt RMS.

3. Should the pass-band coupling coils L13 and L14 require realignment, connect the sweep signal generator directly to the grid of the 6AH6 amplifier tube and the oscilloscope to the grid of the 12BY7A mixer tube through a 47K-ohm isolating resistor. Remove either crystal and switch into the dead position to disable the crystal injection while aligning the unit. Place the transverter in the transmit condition and center the pass-band display about the 23-MC marker by adjusting coils L13 and L14 for maximum display height. Adjust the sweep generator output so that a scope sensitivity of 20 millivolts per centimeter deflection will provide a full size display on a 5-inch diameter oscilloscope tube. Correct alignment is obtained when the 22-MC and 24-MC markers fall at the equal amplitude points on the response curve.

4. With the core adjustment for coil L12 made in step 2 and the pass-band coupling adjusted in step 3, the injection voltages at the grid of the 12BY7A mixer tube should run about four to six volts RMS and be equal to each other within approximately 1/2 volt between the two range positions (transverter in the TRANSMIT condition).

7-5. RECEIVER CONVERTER ALIGNMENT.

The crystal oscillator section must be aligned for equal mixer injection from each RANGE switch position before proceeding with alignment. The receiver converter stages are aligned with the chassis removed from the cabinet.

1. Remove the 5894 tube and disconnect the HV cable.

2. Connect the sweep signal generator to the ANTENNA connector through a 50-ohm calibrated attenuator.

3. Connect the vertical deflection input of the oscilloscope to the junction of coil L3 and resistor R3 through a 47K-ohm isolating resistor. Interconnect the horizontal sweep of the oscilloscope and the sweep signal generator to obtain the synchronized horizontal deflection required.

4. Connect the diode detector unit to the RECEIVER outlet to provide a termination for the transverter mixer output. See figure 11.

5. Center the pass-band about the 52-MC marker by adjusting coils L1, L2, and L3 for maximum display height. Do not stagger-tune the adjustments. Adjust the sweep generator output so that a scope sensitivity of 20 millivolts per centimeter deflection will provide a full size display on a 5-inch diameter oscilloscope tube.

6. The response normally passes through the 1-DB points of the curve at approximately 50 MC and 54 MC, and the peak-to-valley ratio will not exceed 1 DB.

7. If the core position of the mixer grid coil L3 is altered considerably during alignment, recheck crystal injection levels as outlined under Crystal Oscillator Stage Alignment.

8. Disconnect the oscilloscope from the mixer grid circuit and connect the vertical input of the scope to the output of the diode detector unit, which was connected to the RECEIVER outlet in step 4.

9. Switch the RANGE switch to 50 MC to 52 MC (position 1). With the 52-MC marker signal injected, adjust coil L4 for a response centered on the 52-MC marker. Adjust the sweep generator output so that a 10-millivolt per centimeter scope sensitivity will provide a full display on a 5-inch oscilloscope.

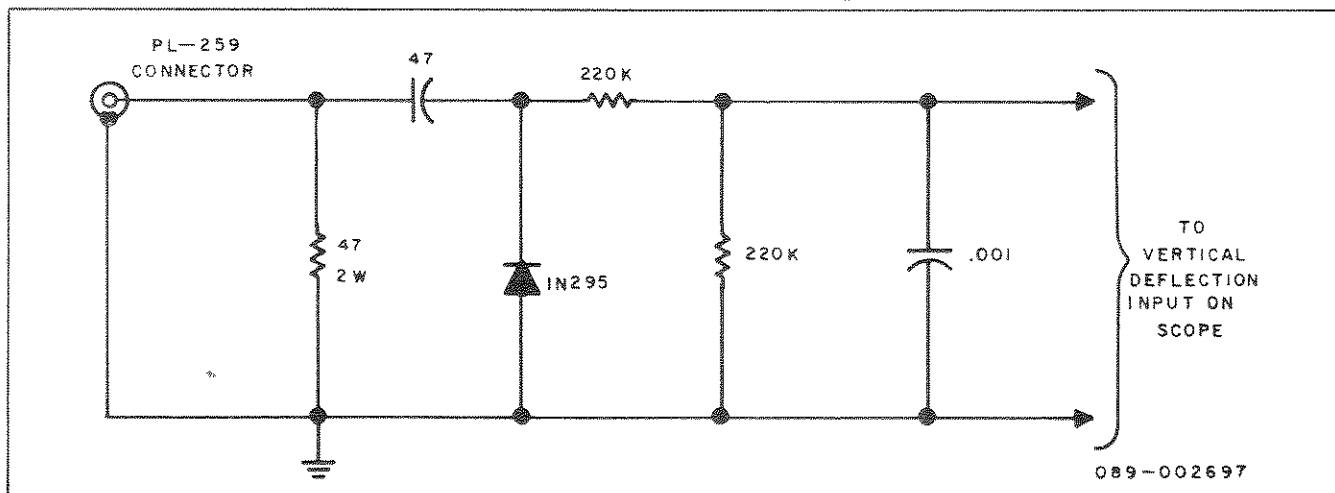
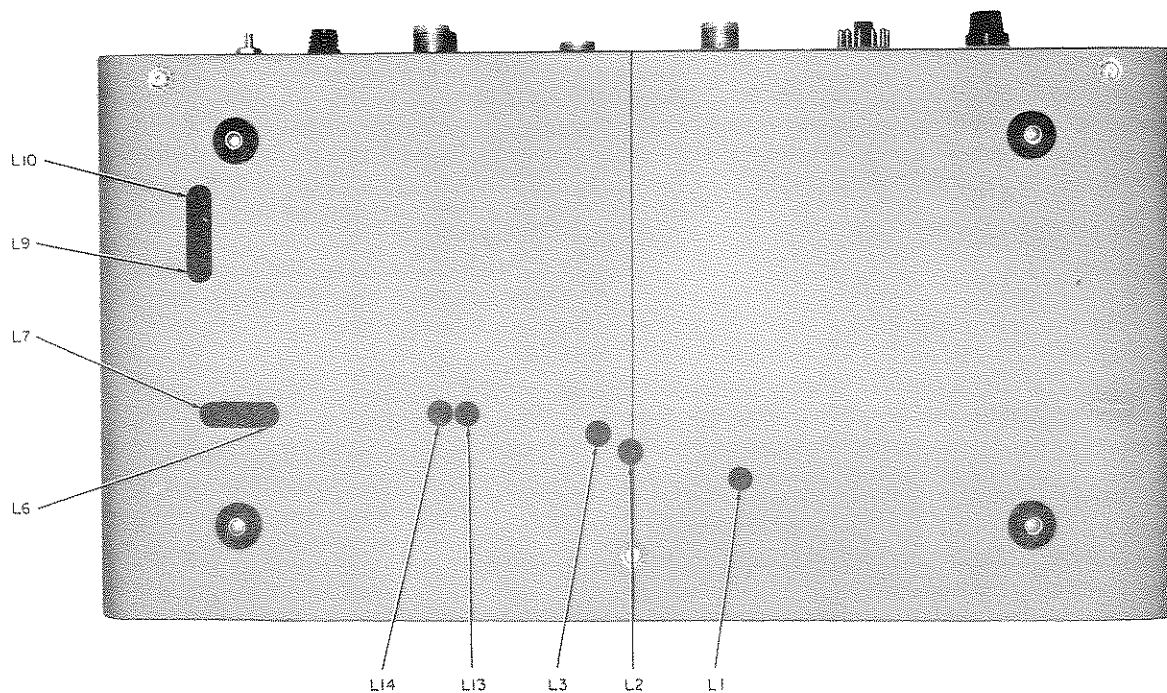

Figure 11. Diode Detector.



The drawing at the right shows the alignment tool to be used when adjusting coils L6, L7, L9, and L10 through the bottom of the cabinet. As the cores of the coils are delicate, do not file the blade of the tool narrower than $\frac{1}{32}$ of an inch or the slot of the core may chip.

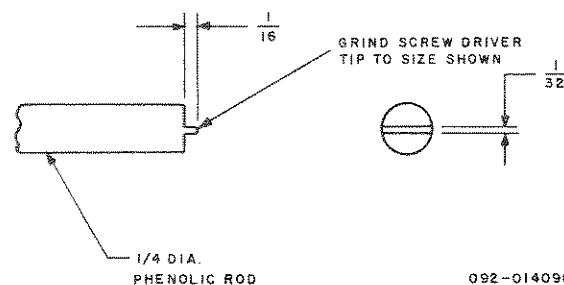

Figure 12. Bottom View of Transverter Cabinet, Showing Alignment Holes.

10. Switch the RANGE switch to 52 MC to 54 MC (position 2) and if necessary, touch up coil L4 for a symmetrical response centered about the 52 MC marker between the two RANGE positions. A difference in peak amplitude of approximately 1-1/2 DB between the two RANGE positions may occur.

11. Normal response runs less than 1-1/2 DB down at 50 MC to 52 MC, and 52 MC to 54 MC for each RANGE control position respectively.

7-6. TRANSMITTER CONVERTER ALIGNMENT.

Note- At the discretion of the operator, the transmitter converter stages may be aligned with the chassis outside of the cabinet. Exercise caution, as many high voltage points are exposed when operating the equipment outside of the cabinet.

1. Connect a 470-ohm, 2-watt, carbon resistor across the final tank coil at the stator lugs of the split-stator capacitor.

2. Install the 5894 tube and assemble the unit in the cabinet. Use ALL mounting screws.

3. Attach the HV cable between the power supply and the transverter unit.

CAUTION

DO NOT INTERCONNECT THE HIGH VOLTAGE CABLE WITH THE POWER SUPPLY TURNED ON.

4. Connect the sweep generator through a 50-ohm calibrated attenuator to the LOW LEVEL INPUT connector.

5. Connect the 47-ohm diode detector unit to the ANTENNA connector. Connect the oscilloscope to the output of the diode detector.

6. Turn on the transverter and allow sufficient time for the idle plate current to stabilize with the transverter in the transmit condition (relay coil return wire grounded).

7. Set the BIAS ADJ. control for a 40-milliampere idle plate current (no signal applied). The bias setting affects overall response; therefore, it must be set before alignment.

8. Set the RANGE switch to 50 MC to 52 MC (position 1).

9. Set the frequency of the sweep generator to sweep the 28-MC to 32-MC range. Adjust the output level to fill a 5-inch oscilloscope tube with scope sensitivity set for 20 millivolts per centimeter.

10. Inject a 30-MC marker signal.

11. Adjust LOAD and TUNE controls for maximum display amplitude. Note that the controls rock the pass-band as they are tuned through maximum. Watch the 30-MC marker (52-MC output) and set the controls for maximum at this point of the curve.

12. Adjust coils L6, L7, L9, and L10 for maximum amplitude centered about the 30-MC (52-MC output) marker. Do not stagger-tune the adjustments.

CAUTION

DO NOT BLOCK OFF THE AIR INTAKE AND EXHAUST OPENINGS IN THE CABINET SIDES WHEN OPERATING WITH THE UNIT SET ON END TO REACH THE ALIGNMENT OPENINGS AT THE BOTTOM OF THE CABINET. PROP UP THE CABINET SIDE WHICH RESTS ON THE BENCH TOP SO THAT AIR CAN FLOW UP THROUGH THE UNIT.

13. Normal response will be less than 1 DB down at the 28-MC (50-MC output) and 32-MC (54-MC output) markers. The peak-to-valley ratio will be less than 1 DB.

14. Remove the 470-ohm, 2-watt resistor before making any operating checks after alignment.

7-7. TRAP ADJUSTMENT.

A 48-MC trap has been placed in the plate circuit of the 12BY7A mixer tube to attenuate the second harmonic of the 24-MC crystal injection required for the 52 MC to 54 MC frequency range. Readjustment of the 48-MC trap L5 is indicated if a five to ten milliampere increase in idle plate current occurs when the RANGE switch is switched from position 1 to position 2.

1. Remove the chassis from the cabinet and connect the POWER and HIGH VOLTAGE cables to the unit.

CAUTION

Operating the equipment outside of the cabinet exposes the operator to 750 VDC. Exercise extreme care while performing the following adjustments.

2. Allow sufficient time for the equipment to reach operating temperature and check the idle plate current in the 50 MC to 52 MC RANGE position. Set the idle plate current at 40 milliamperes, if necessary, with the BIAS ADJ. control (R44).

3. Set RANGE control at 52 MC to 54 MC and note the idle plate current. If it increases, adjust the pitch of the trap coil L5 for minimum idle plate current. Normally, the idle plate current in position 2 of the RANGE switch will be the same as in position 1 when the trap is correctly tuned to 48 MC (second harmonic of the 24-MC crystal). For this adjustment, use an insulated tool made of dry wood or phenolic similar to the alignment tool shown in figure 12.

4. A more refined adjustment of the trap may be obtained by terminating the transverter in a 50-ohm dummy load metered with a vacuum tube voltmeter. Adjust the TUNE and LOAD controls for maximum harmonic voltage across the load before adjusting the trap coil for minimum output voltage (RANGE control set at 52 MC to 54 MC range).

If an idle plate current increase still occurs after adjusting the trap, check the injection voltage levels at the grid of the 12BY7A mixer tube as outlined in paragraph 7-4.

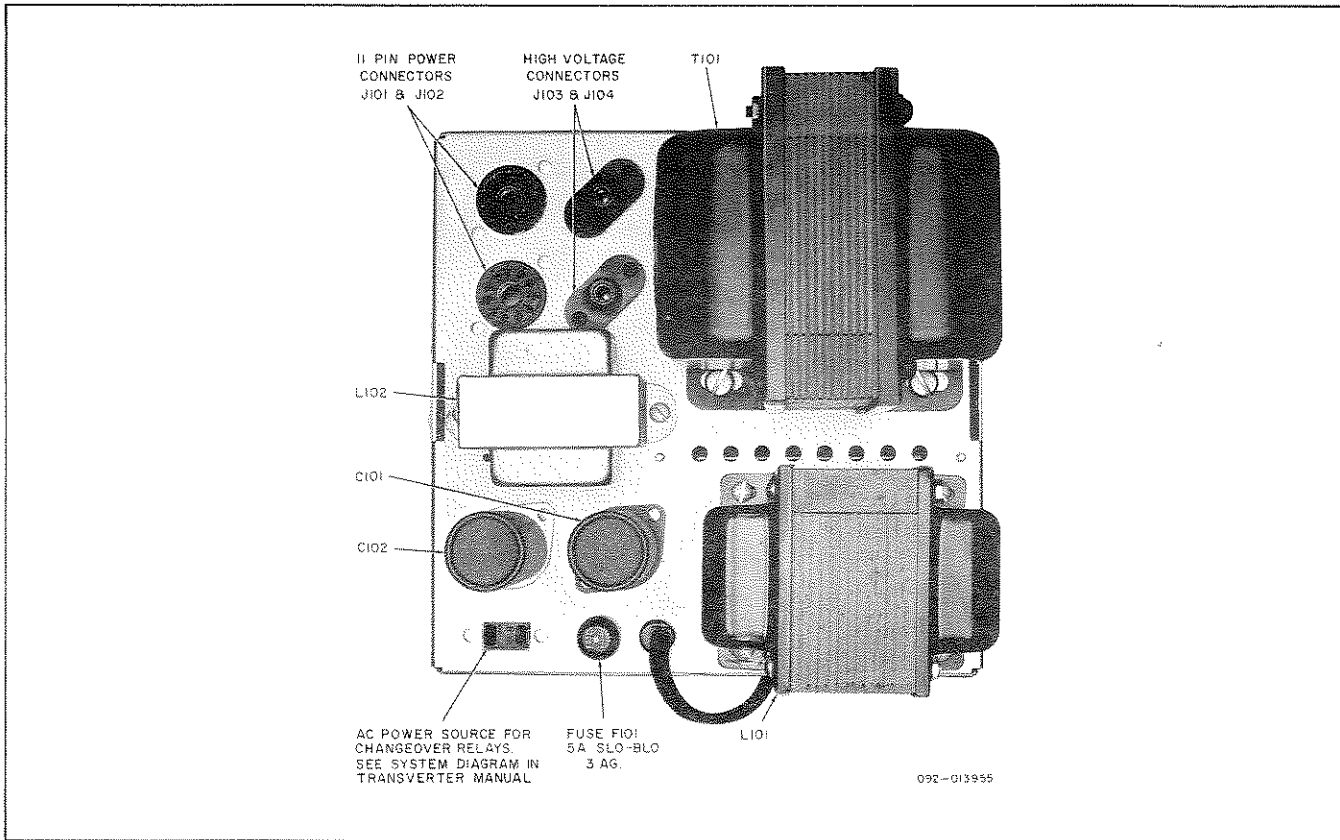

Figure 13. Top View of P-26 Power Supply.

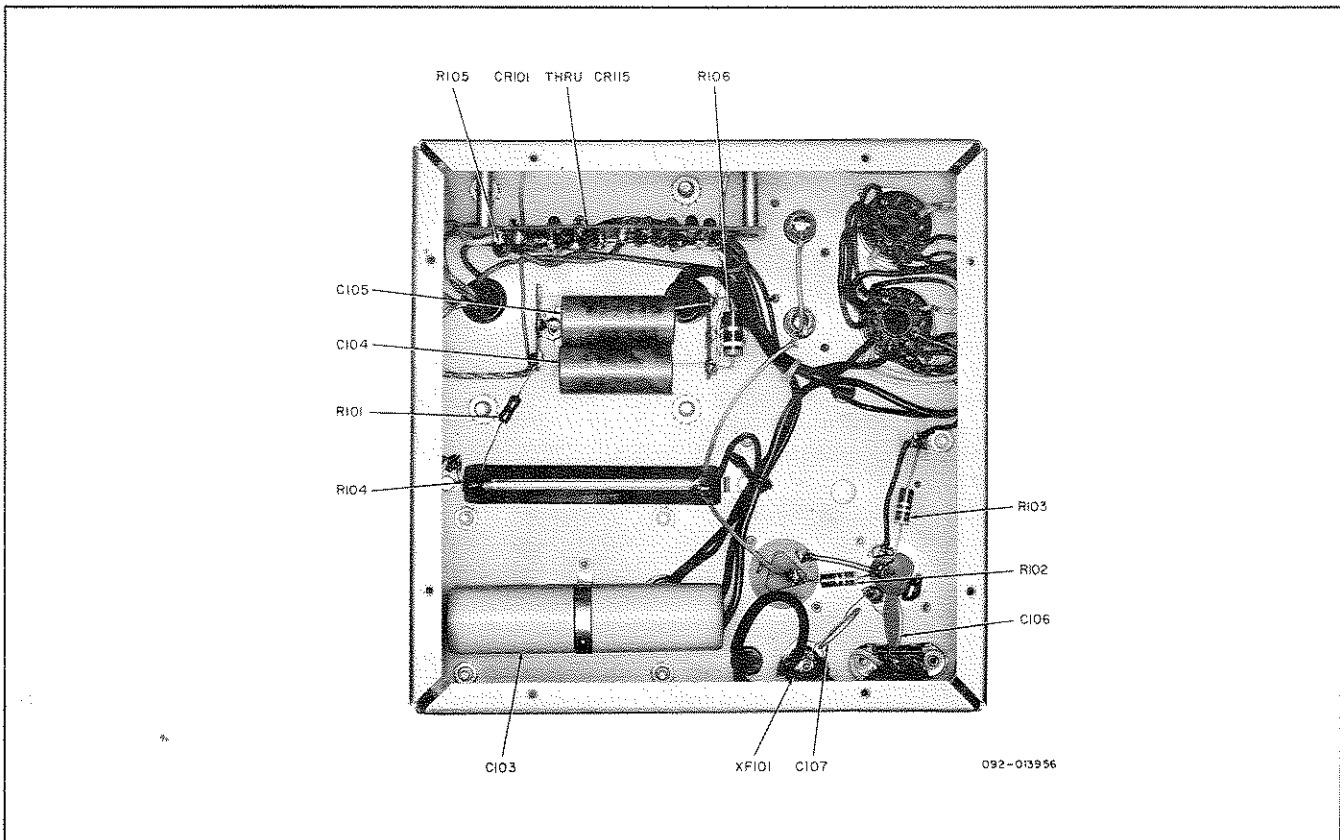

Figure 14. Bottom View of P-26 Power Supply.

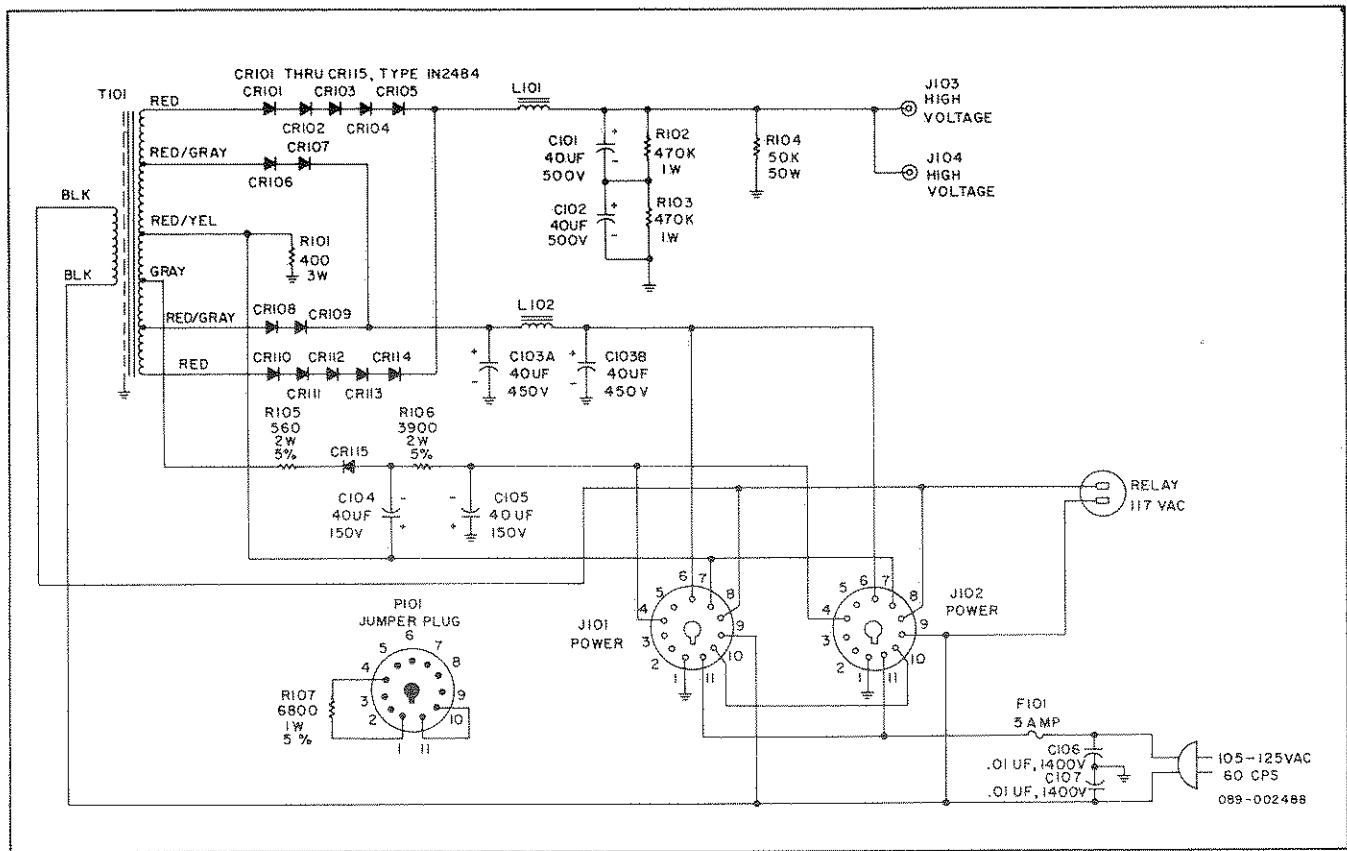

Figure 15. Schematic Diagram of Model P-26 Power Supply.

MODEL P-26 SERVICE REPAIR PARTS LIST

Schematic Symbol	Description	Hallicrafters Part Number	Schematic Symbol	Description	Hallicrafters Part Number
R101	Resistor, Wire wound, 400 ohm, 5%, 3 watt	448-011401	C101,102	Capacitor, Electrolytic, 40 μ F, 500V	045-000782
R102,103	Resistor, Composition, 470K ohm, 10%, 1 watt	451-352474	C103A,B	Capacitor, Electrolytic, 40 x 40 μ F, 450V	045-000794
R104	Resistor, Wire wound, 50K ohm, 5%, 50 watt	024-001408	C104,105	Capacitor, Electrolytic, 40 μ F, 150V	045-200509
R105	Resistor, Composition, 560 ohm, 5%, 2 watt	451-651561	C106,107	Capacitor, Ceramic Disc 0.01 μ F, 1400V	047-001309
R106	Resistor, Composition, 3900 ohm, 5%, 2 watt	451-651392	*CR101,102, 103,104,105, 106,107,108, 109,110,111, 112,113,114, 115	Rectifier, Silicon, Type 1N2484	019-002634
R107	Resistor, Composition, 6800 ohm, 5%, 1 watt	451-351682	F101	Fuse, 5 ampere, 3AG	039-100460
T101	Transformer, Power Feet, Rubber Fuseholder Line Cord Lock, Line Cord Plate, Bottom Plug Assembly, Jumper (11-pin) (Inc. P101 and R107) Strap, Nylon	052-000924 016-200983 006-200845 087-204690 076-100953 063-005442 150-003323 076-102950	J101,102 J103,104 L101 L102 P101	Socket, Power (11-pin) Connector, High Voltage Coil, Choke, Swinging Filter, 8 to 27 henry Coil, Choke, Filter, Smoothing, 9 henry Plug, 11-Pin	006-100707 010-002257-2 056-000476 056-000477 035-100043

*Silicon rectifier types with PIV rating of 600V and recurrent peak current rating of 7.5A. may be used as alternates for repairs in the field.

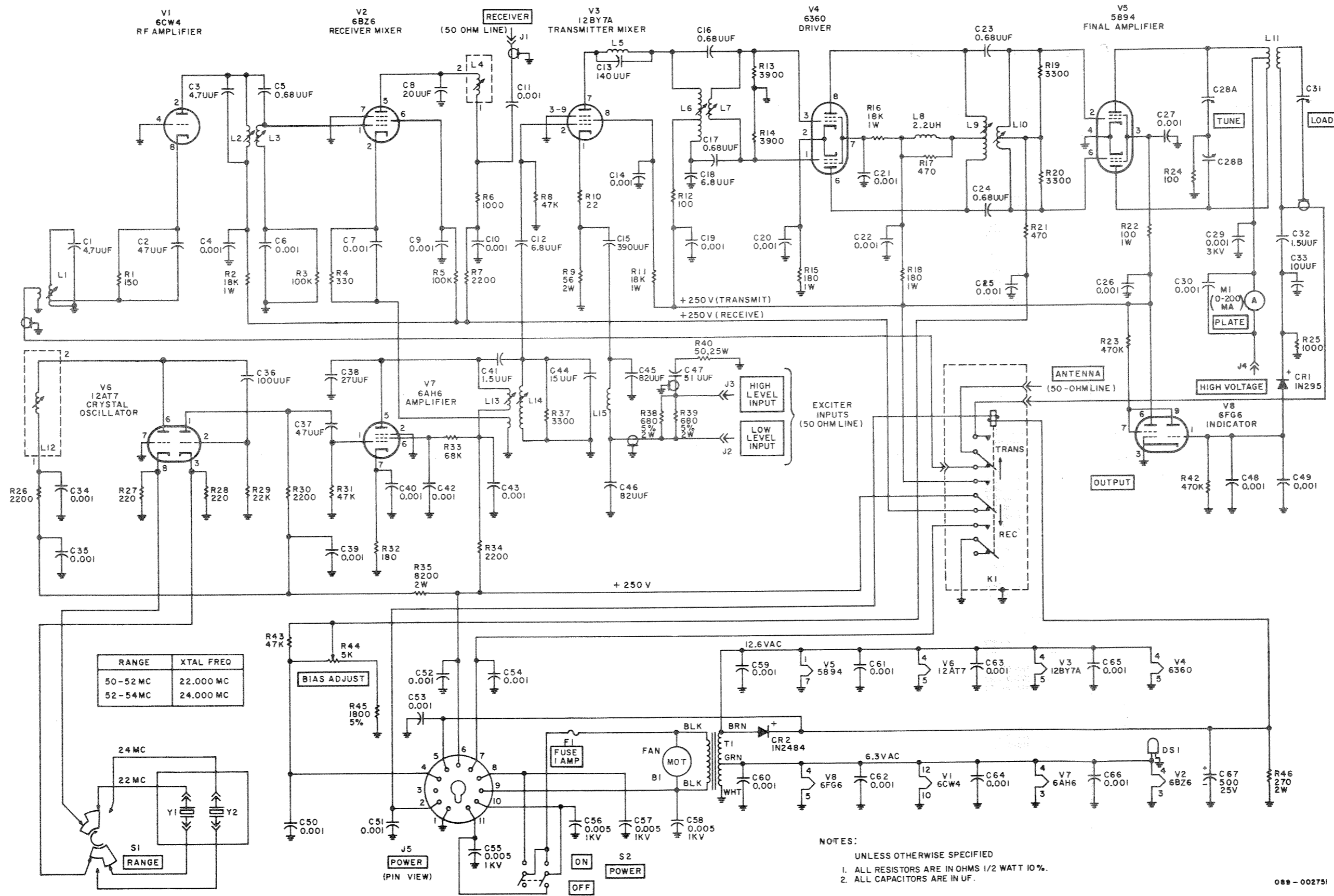

Figure 16. Schematic Diagram of the Model HA-6 Six-Meter Transverter.

MODEL HA-6 SERVICE REPAIR PARTS LIST

Reference Symbol	Description	Hallicrafters Part Number	Reference Symbol	Description	Hallicrafters Part Number	Reference Symbol	Description	Hallicrafters Part Number
<u>CAPACITORS</u>			<u>RESISTORS* (CONT.)</u>			<u>MISCELLANEOUS</u>		
C1,3	4.7 μ f, 500V, Plastic Mica	482-135047	R12,24	100 ohm	451-252101		Base, Shield (9-pin socket)	069-001417
C2,37	47 μ f, 5%, 500V, Plastic Mica	482-152470	R13,14	3900 ohm	451-252392		Base, Shield (7-pin socket)	069-001550
C4,6,7,9,10,11,14,19,20,21,22,25,26,27,30,34,35,39,40,42,43,48,49,50,51,52,53,54,59,60,61,62,63,64,65,66	0.001 μ f, GMV, 500V, Ceramic Disc	047-200230	R15,18	180 ohm, 1 watt	451-352181		Blade, Fan	080-000782
C5,16,17,23,24	0.68 μ f, 10%, 500V, Composition	047-200403-1	R17,21	470 ohm	451-252471		Bracket, Capacitor Mounting (C28)	067-009342
C8	20 μ f, 2%, 500V, Plastic Mica	482-151200	R19,20,37	3300 ohm	451-252332		Bracket, Capacitor Mounting (C31)	067-009753
C12,18	6.8 μ f, 500V, Plastic Mica	482-135068	R22	100 ohm, 1 watt	451-352101		Bracket, Fan Motor Mtg.	067-009760
C13	140 μ f, 2%, 500V, Plastic Mica (Part of trap coil L5)	482-161141	R23,42	470K ohm	451-252474		Bracket, Meter Mounting	067-205738
C15	390 μ f, 5%, 500V, Plastic Mica	482-162391	R27,28	220 ohm	451-252221		Cabinet	150-002192
C28A&B	Variable, TUNE	048-000520	R29	22K ohm	451-252223		Cable Assembly, HV Supply	087-007137
C29	0.001 μ f, 20%, 3000V, Ceramic Disc	047-100397	R32	180 ohm	451-252181		Cable Assembly, Power	087-007135
C31	Variable, LOAD	048-000532	R33	68K ohm	451-252683		Clip, Fahstock	076-003707
C32	1.5 μ f, \pm 0.25 μ f, NPO, 500V, Ceramic Tubular	491-001015-22	R35	8200 ohm, 2 watt	451-652822		Connector, Coaxial	010-100056
C33	10 μ f, 20%, 500V, Ceramic Feed-Through	047-001636	R38,39	680 ohm, 5%, 2 watt	451-651681	J1,2,3	Connector, High Voltage	010-002257-2
C36	100 μ f, 5%, 500V, Plastic Mica	482-162101	R40	50 ohm, 5%, 25 watt, wire wound	024-001402	J4	Core, Coil Tuning (L1, 2, 3, 13, 14)	077-002267
C38	27 μ f, 2%, 500V, Plastic Mica	482-151270	R44	Variable, 5000 ohm, 20%, 3/4 watt, BIAS ADJUST	025-002023		Core, Coil Tuning (L6, 7)	077-002899
C41	1.5 μ f, 10%, 500V, Composition	047-200403-3	R45	1800 ohm, 5%	451-251182		Core, Coil Tuning (L9, 11)	077-002701
C44	15 μ f, 5%, 500V, Plastic Mica	482-132150	R46	270 ohm, 2 watt	451-652271		Core, Coil Tuning (L4, 12)	003-101510
C45,46	82 μ f, 2%, 500V, Plastic Mica	482-161820	* All RESISTORS are carbon type, 10%, 1/2 watt unless otherwise stated.				Crystal Mounting Board Assembly	150-005226
C47	51 μ f, 5%, 500V, Plastic Mica	482-152510	<u>COILS AND TRANSFORMERS</u>			Y1	Crystal, Quartz (22900.000 KC)	019-002905
C55,56,57,58	0.005 μ f, GMV, 1000V, Ceramic Disc	047-100485	L1	Transformer, Antenna	051-003360	Y2	Crystal, Quartz (24900.000 KC)	019-002906
C67	500 μ f, 25V, Electrolytic	045-000784	L2	Coil, RF Amplifier Plate (Receiver)	051-003361	F1	Foot, Mounting (4)	016-200983
<u>RESISTORS*</u>			L3	Coil, Mixer Grid (Receiver)	051-003362		Front Panel	150-003888
R1	150 ohm	451-252151	L4	Coil, Mixer Plate (Receiver)	051-003259		Fuse, 1 Ampere, 3 AG	039-100306
R2,11,16	18K ohm, 1 watt	451-352183	L5	Coil, 48-MC Trap (Including capacitor C13)	053-000657		Fuse Holder	006-200845
R3,5	100K ohm	451-252104	L6	Coil, Mixer Plate (Transmitter)	051-003364		Insulator, Stand-off	008-007090
R4	330 ohm	451-252331	L7	Coil, Driver Grid	051-003369	M1	Knob, LOAD and TUNE	015-001724
R6,25	1000 ohm	451-252102	L8	Coil, RF Choke (2.2 μ h)	053-000641		Knob, RANGE and POWER	015-001725
R7,26,30,34	2200 ohm	451-252222	L9	Coil, Driver Plate	051-003365	B1	Lamp, Pilot No. 47	039-100004
R8,31,43	47K ohm	451-252473	L10	Coil, Final Amplifier Grid	051-003366		Meter, PLATE current (0-200 MA)	082-000552
R9	56 ohm, 2 watt	451-652560	L11	Coil, Final Amplifier Plate	051-003385		Motor, Fan	020-000321
R10	22 ohm	451-252220	L12	Coil, Crystal Oscillator Plate	051-003371	K1	Plug Assembly, Type PL-259	010-100173
			L13	Coil, Crystal Amplifier Plate	051-003368		Plug Adapter, Type UG-175/U	010-100371
			L14	Coil, Mixer Grid (Transmitter)	051-003370		Relay, Coaxial, 12 VDC	021-000606
			L15	Coil, Low-Pass Filter	051-003285		Ring, Retaining (Shafts)	076-100552
			T1	Transformer, Filament	052-000923		Shaft, Capacitor Adjust (C31)	074-002564
			<u>ELECTRON TUBES AND DIODES</u>				Shaft, Variable Capacitor (C28)	074-002573
			V1	Tube, 6CW4, RF Amplifier	090-001462	XV1	Shield, Pilot Lamp	086-100037
			V2	Tube, 6BZ6, Receiver Mixer	090-001499	XV2,7	Shield, RF	069-001502
			V3	Tube, 12BY7A, Transmitter Mixer	090-901192		Shield, Top	069-001503
			V4	Tube, 6360, Driver	090-901253	XV5	Shield, Tube (V6)	069-201190
			V5	Tube, 5894, Final Amplifier	090-900642		Shield, Tube (V2,7)	069-201191
			V6	Tube, 12AT7, Crystal Oscillator	090-900034	J5	Shield, Tube (V3,4)	069-001590
			V7	Tube, 6AH6, Crystal Amplifier	090-900793	S1	Socket, Nuvistor	006-000936
			V8	Tube, 6FG6, Indicator	090-001463		Socket, Tube, 7-pin Min.	006-000946
			CR1	Diode, Type 1N295	019-301980		Socket, Tube, 9-pin Min.	006-000947
			CR2	Diode, Silicon, Type 1N2484	019-002634		Socket, Tube	006-000999
							Socket, Pilot Lamp	086-000591
							Socket, Power (11-Pin)	006-200793
							Spring, Tension (V5)	075-000901
							Switch, Rotary, Wafer (RANGE)	060-002527
							Switch, Rotary, DPDT (POWER)	060-002405
							Trim Strip	007-000818